

(End)

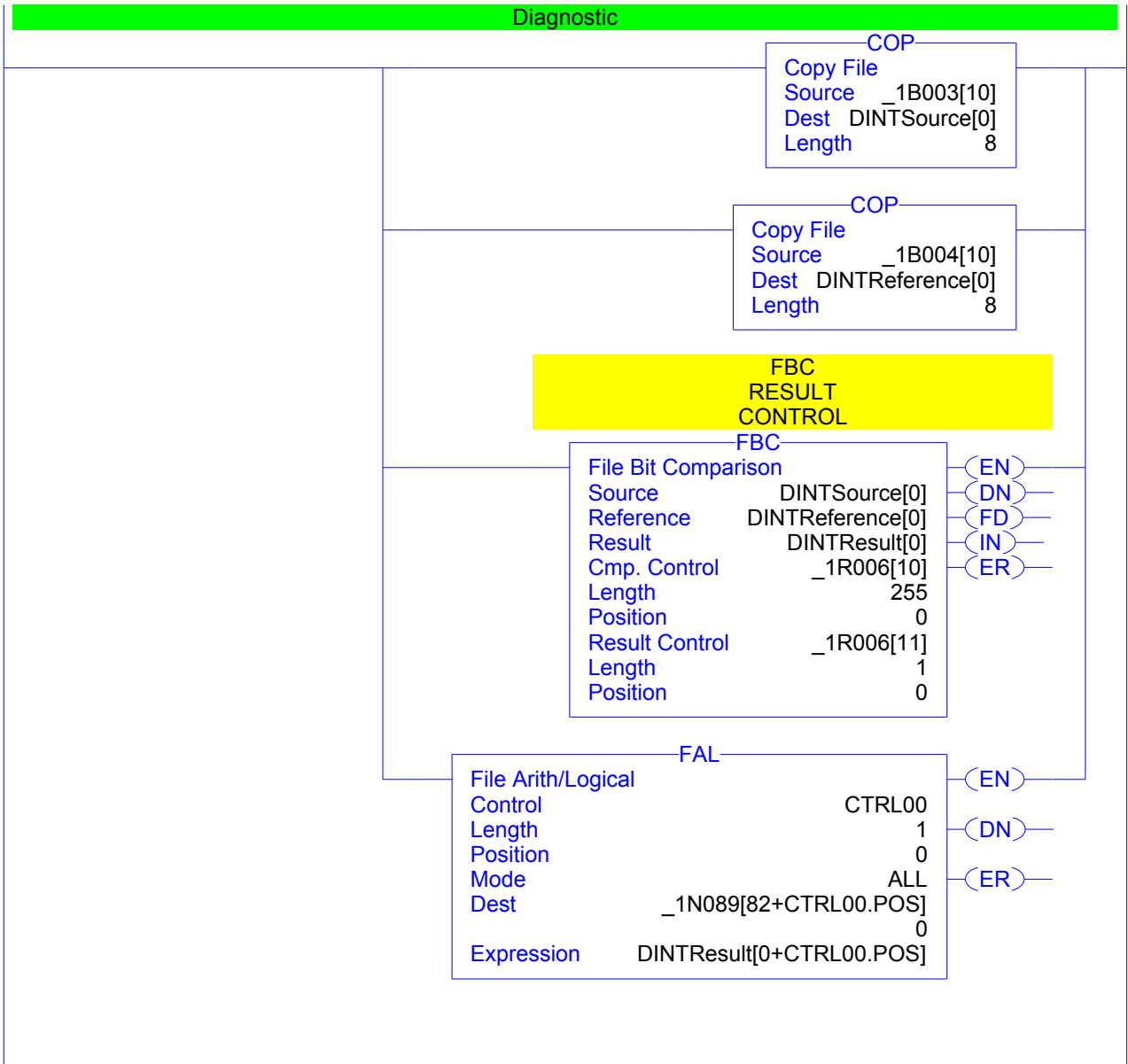

0



1

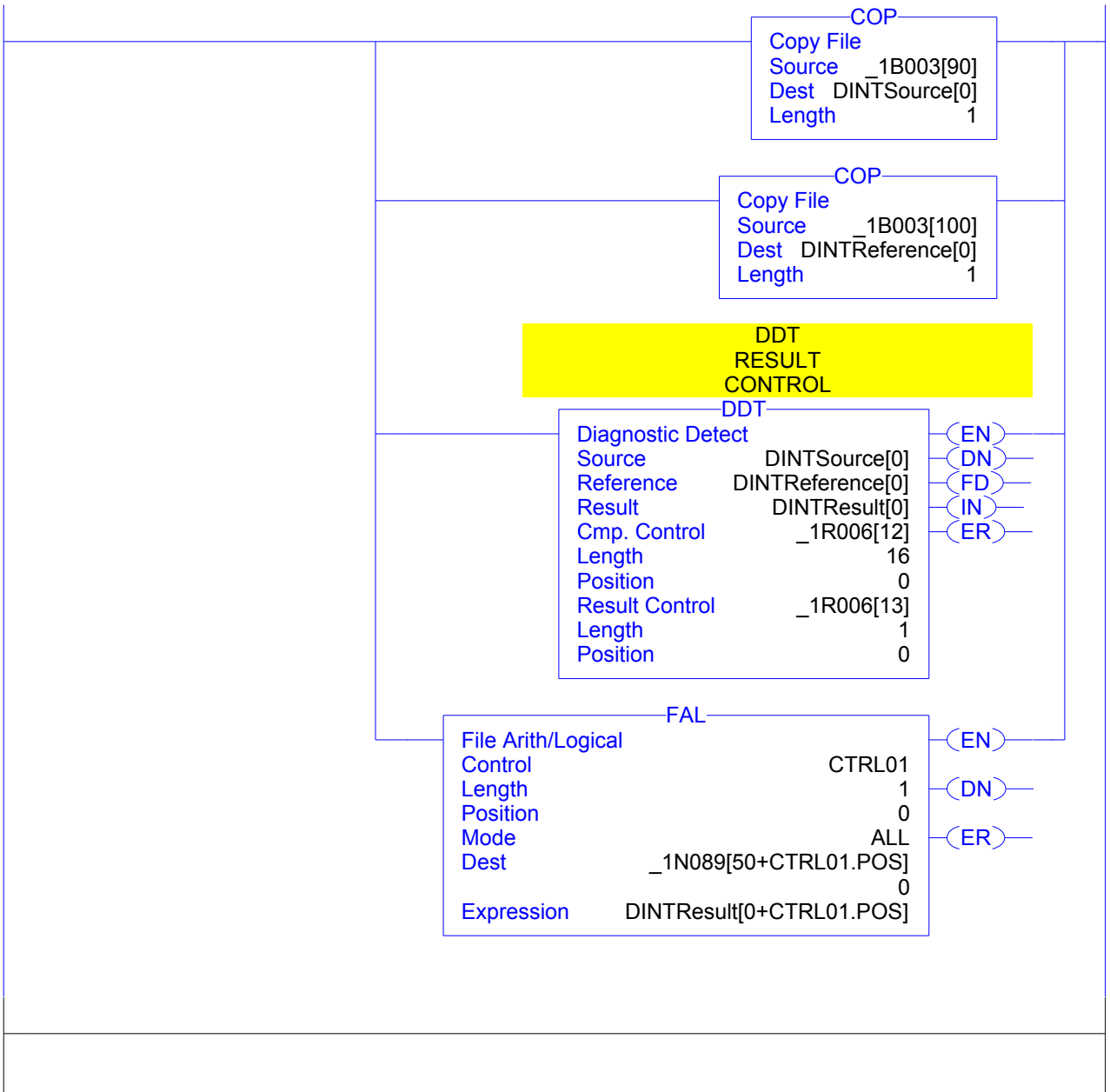

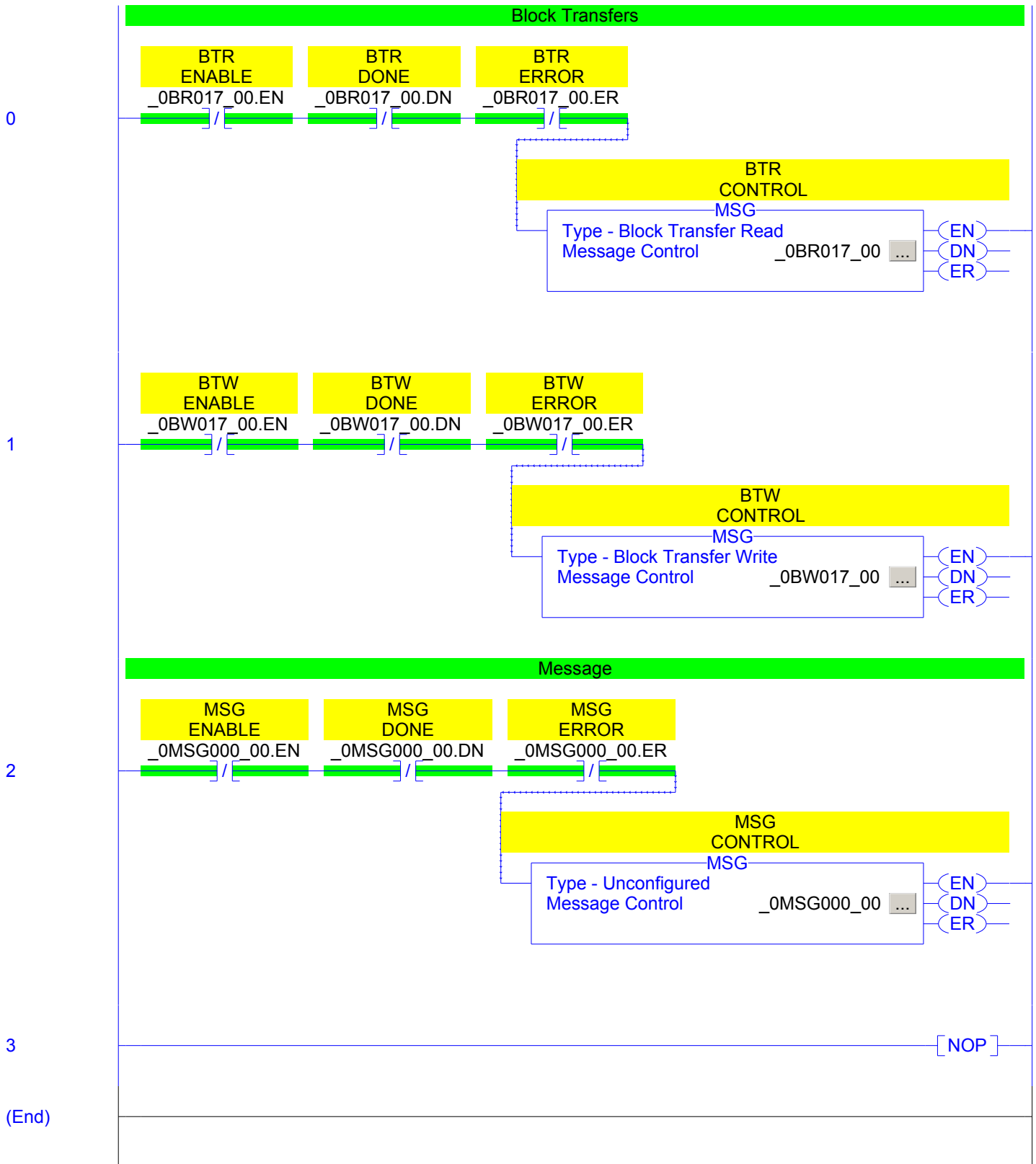

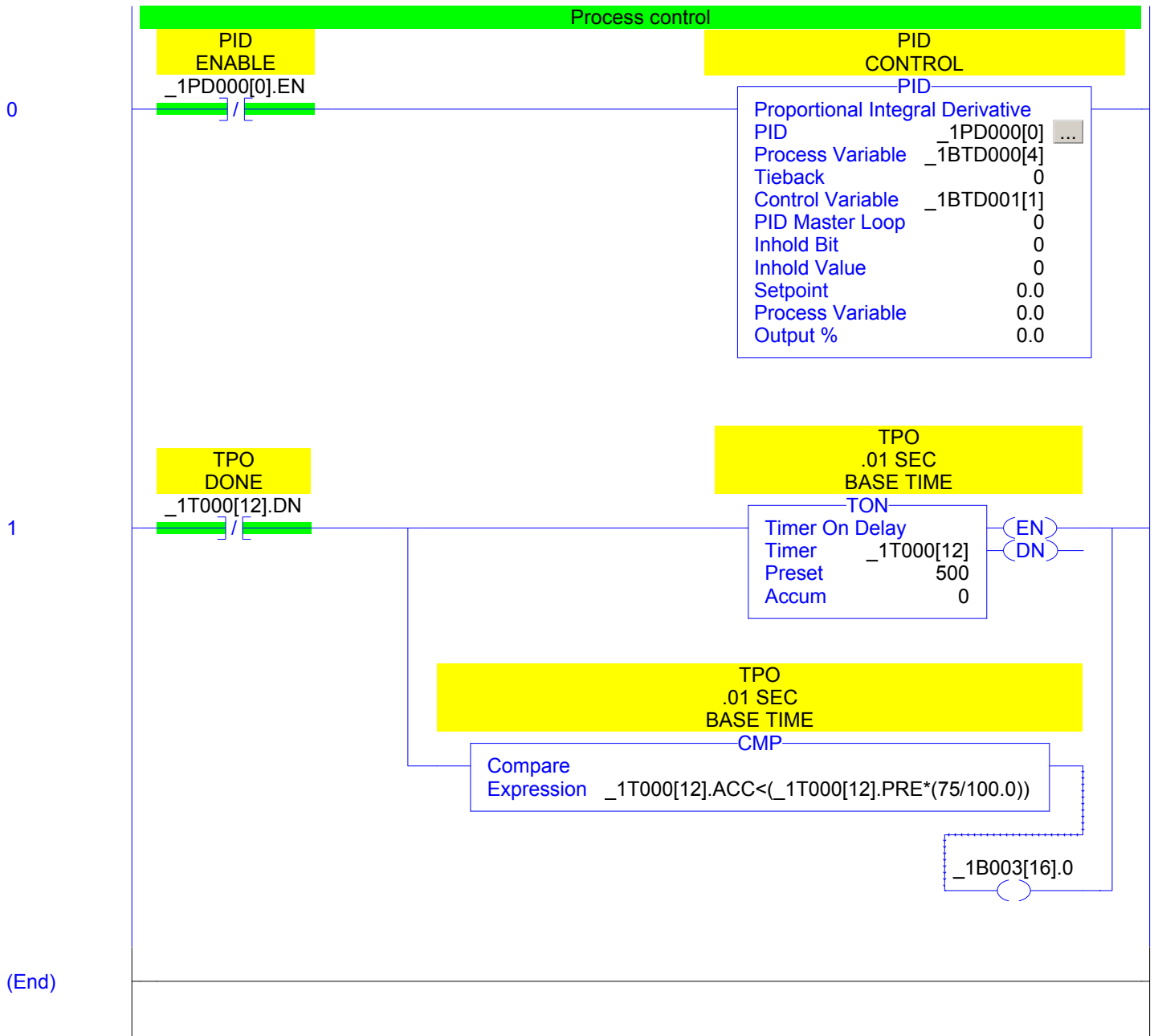

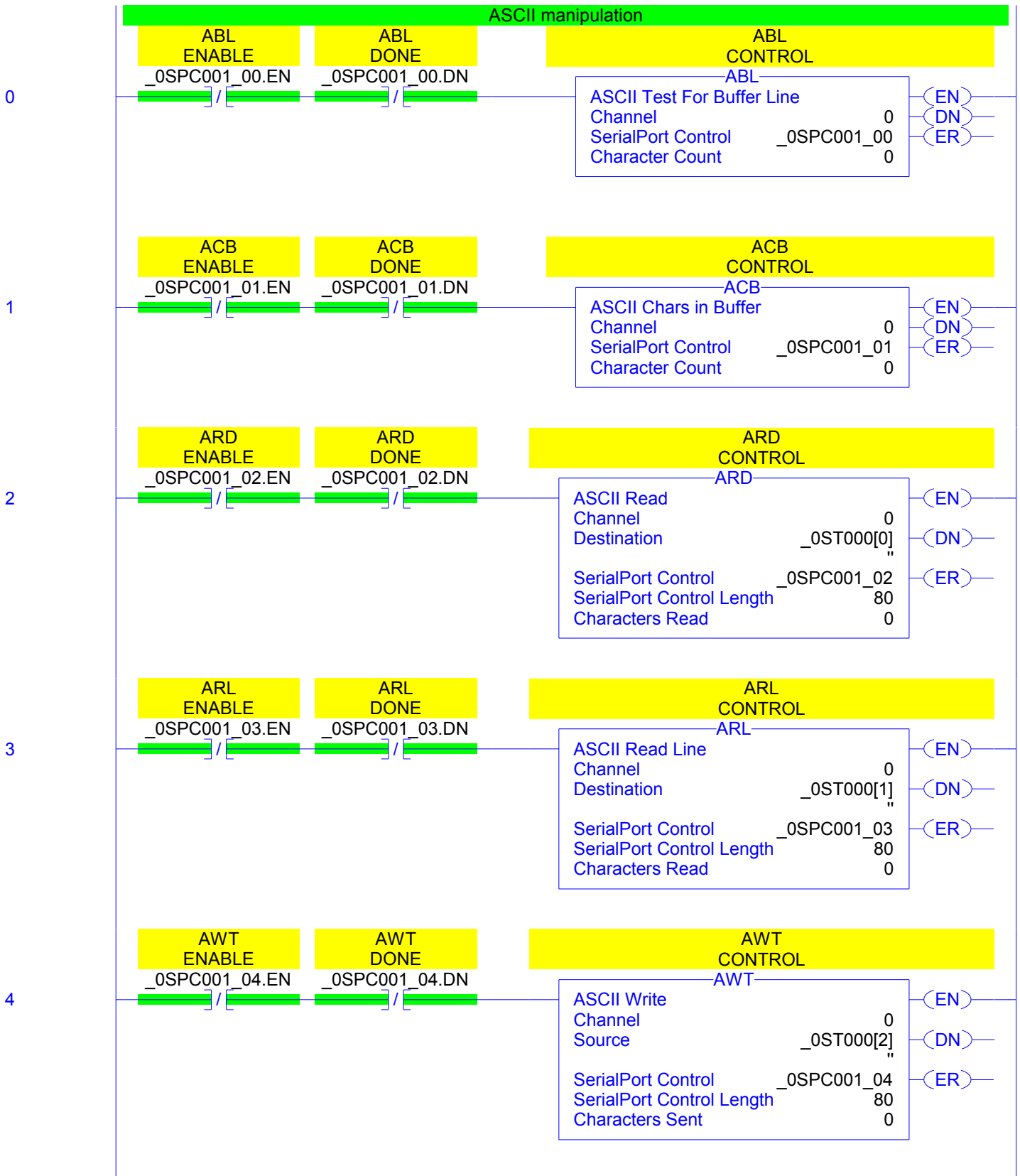

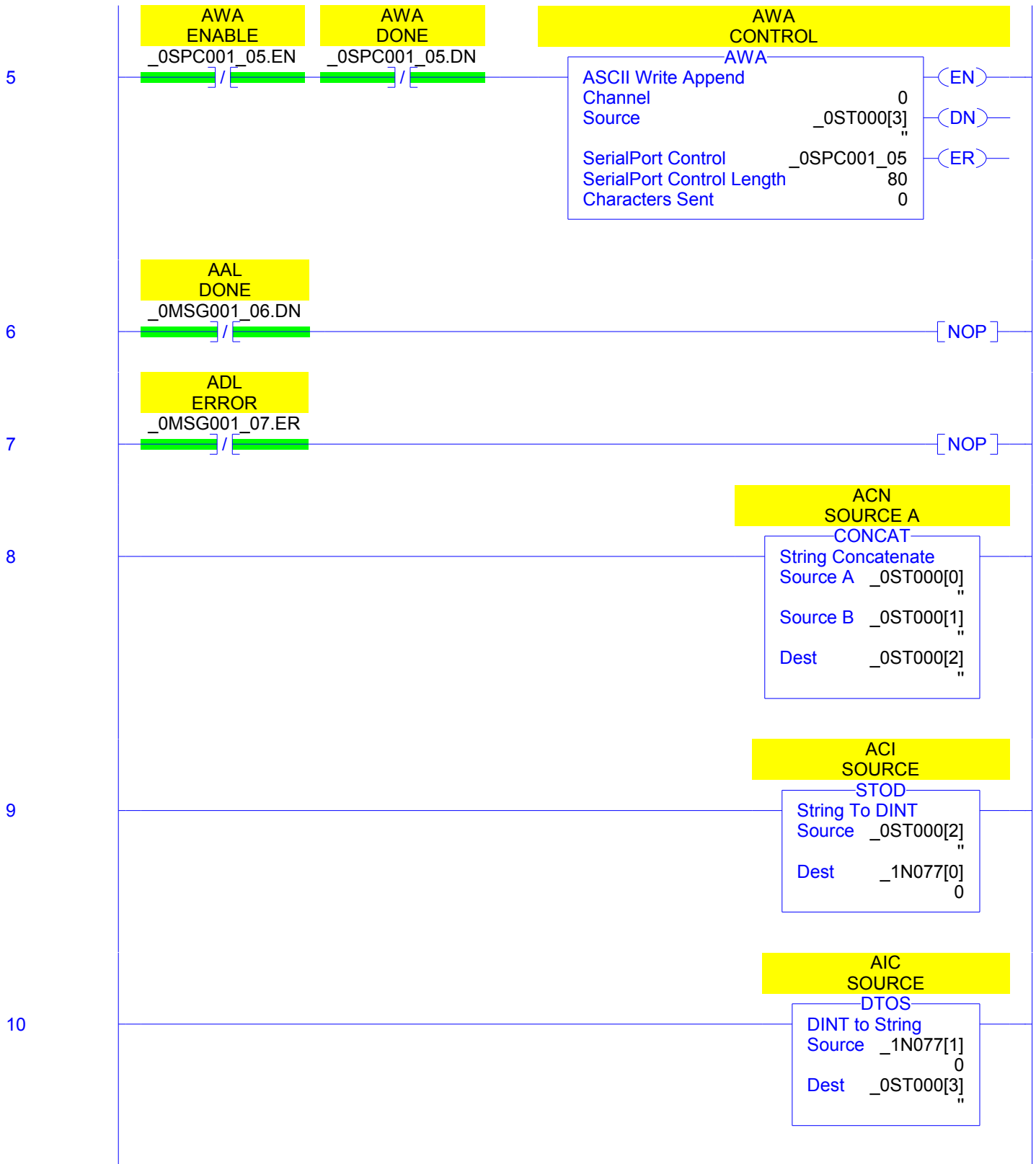

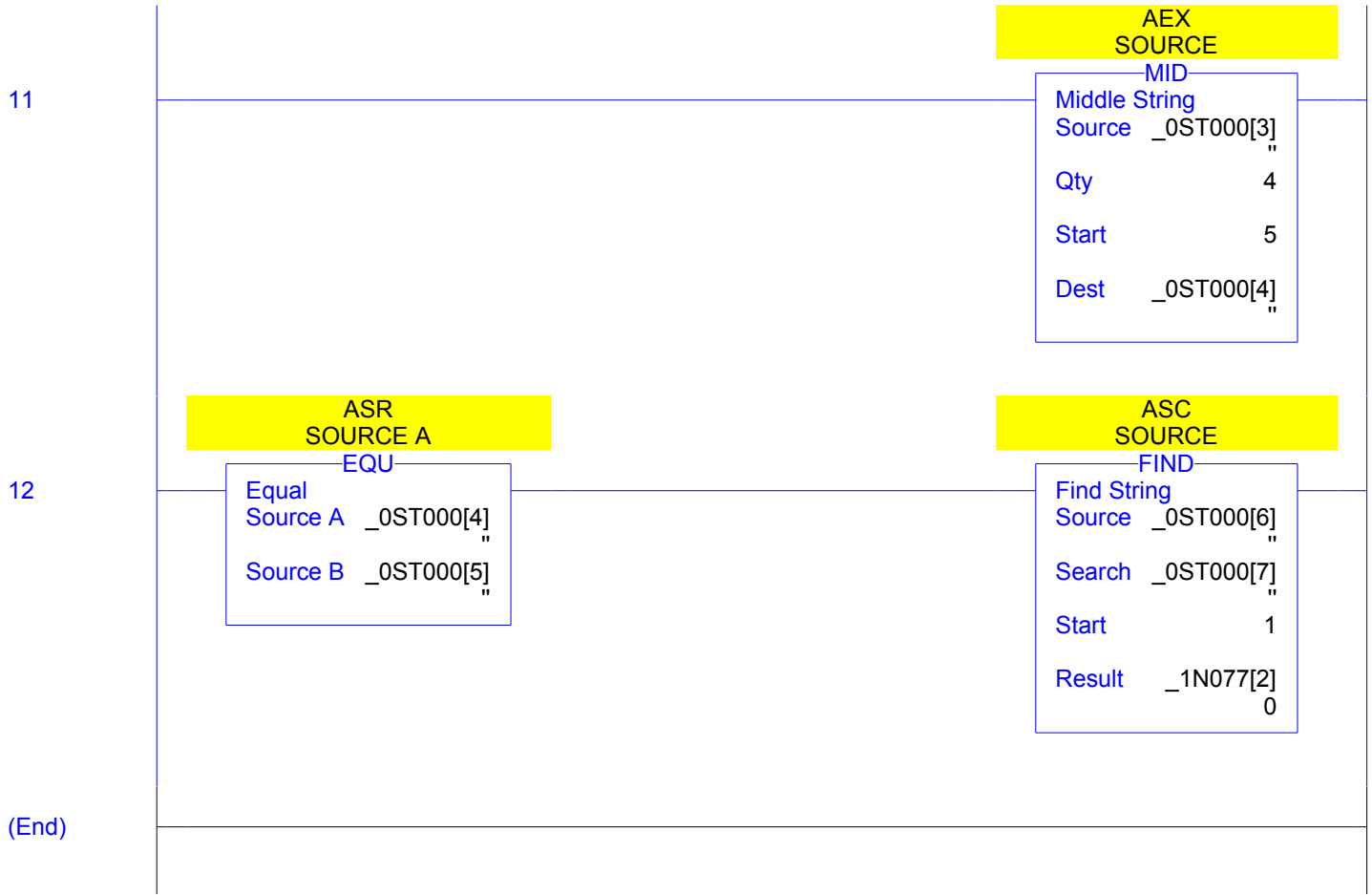

This is a rung comment.

This program is totally useless...
as far as controlling any process. Now on the other hand if you would like to see how different instructions are converted read on.

This program was converted using the DHRIO option. The racks get converted to full racks on a universal Remote I/O. Bits in the rack range will be remapped to I/O. Bits outside of this range will point to the INT array.

I/O bit addresses use the format: `_RRS:I.Data[M].B`
where:
RR = rack in octal
S = Starting module group
I = Input (or O for output)
M = Module group offset
B = Terminal number in decimal

This section of rungs show how bits are converted.

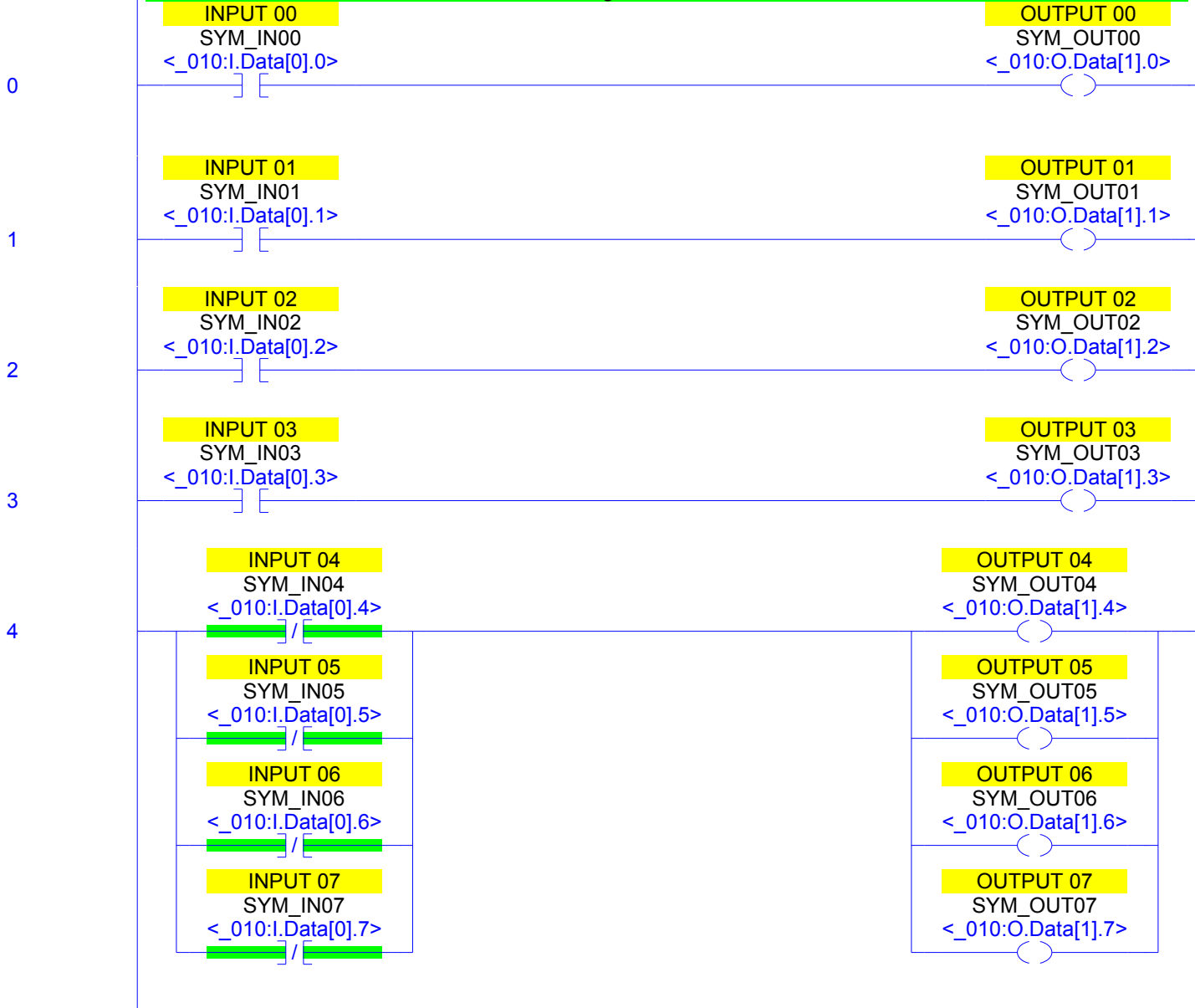

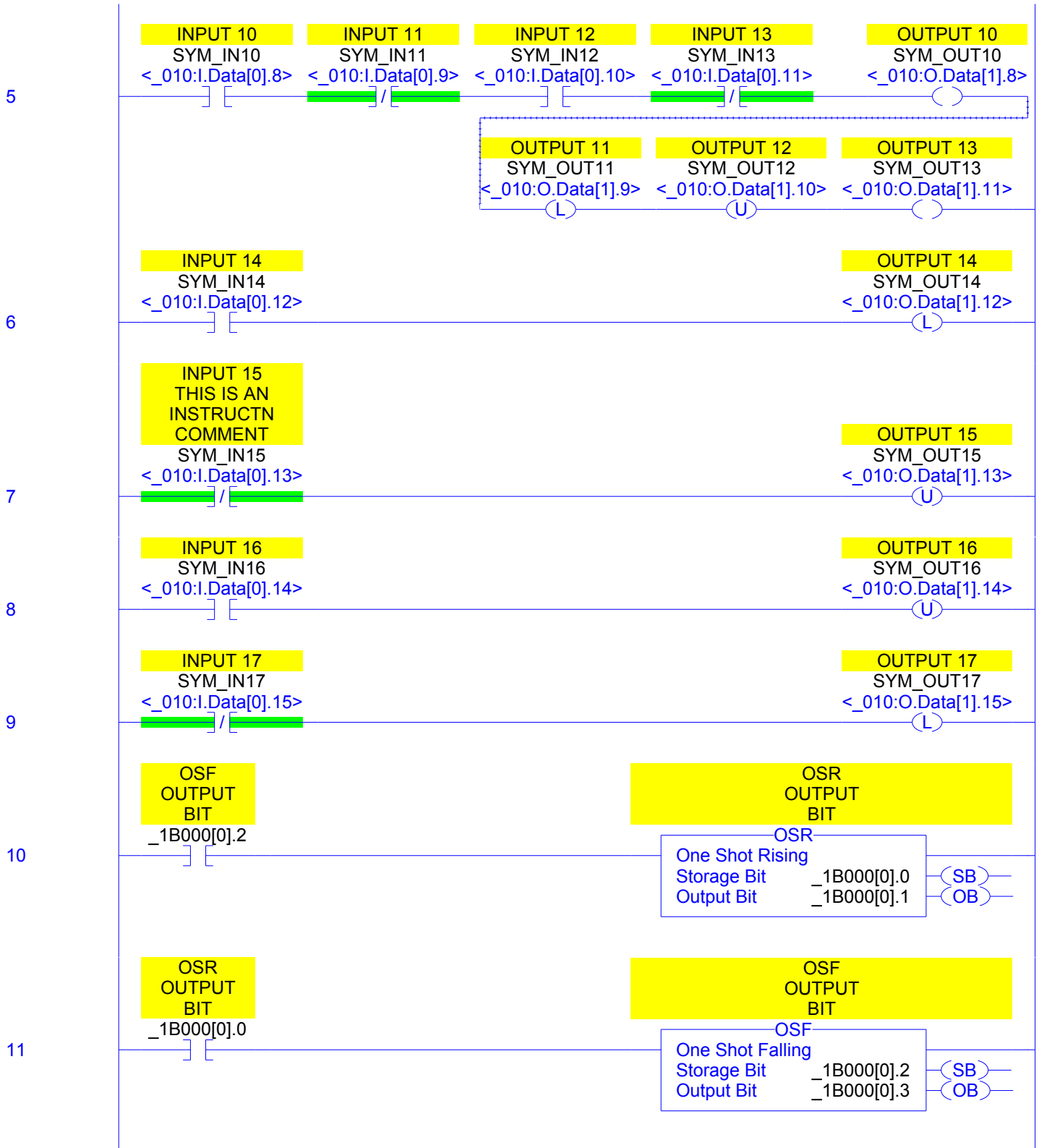

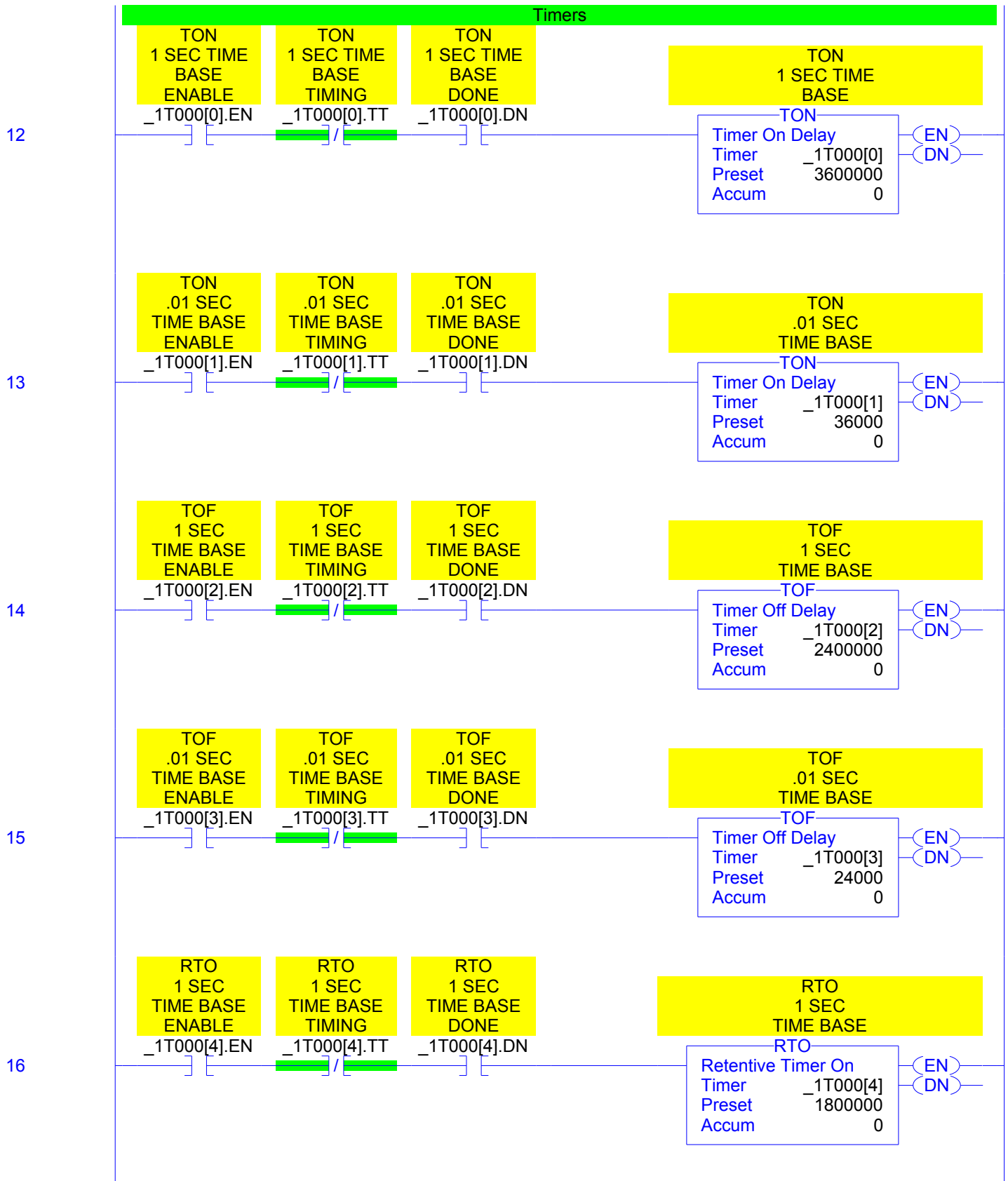

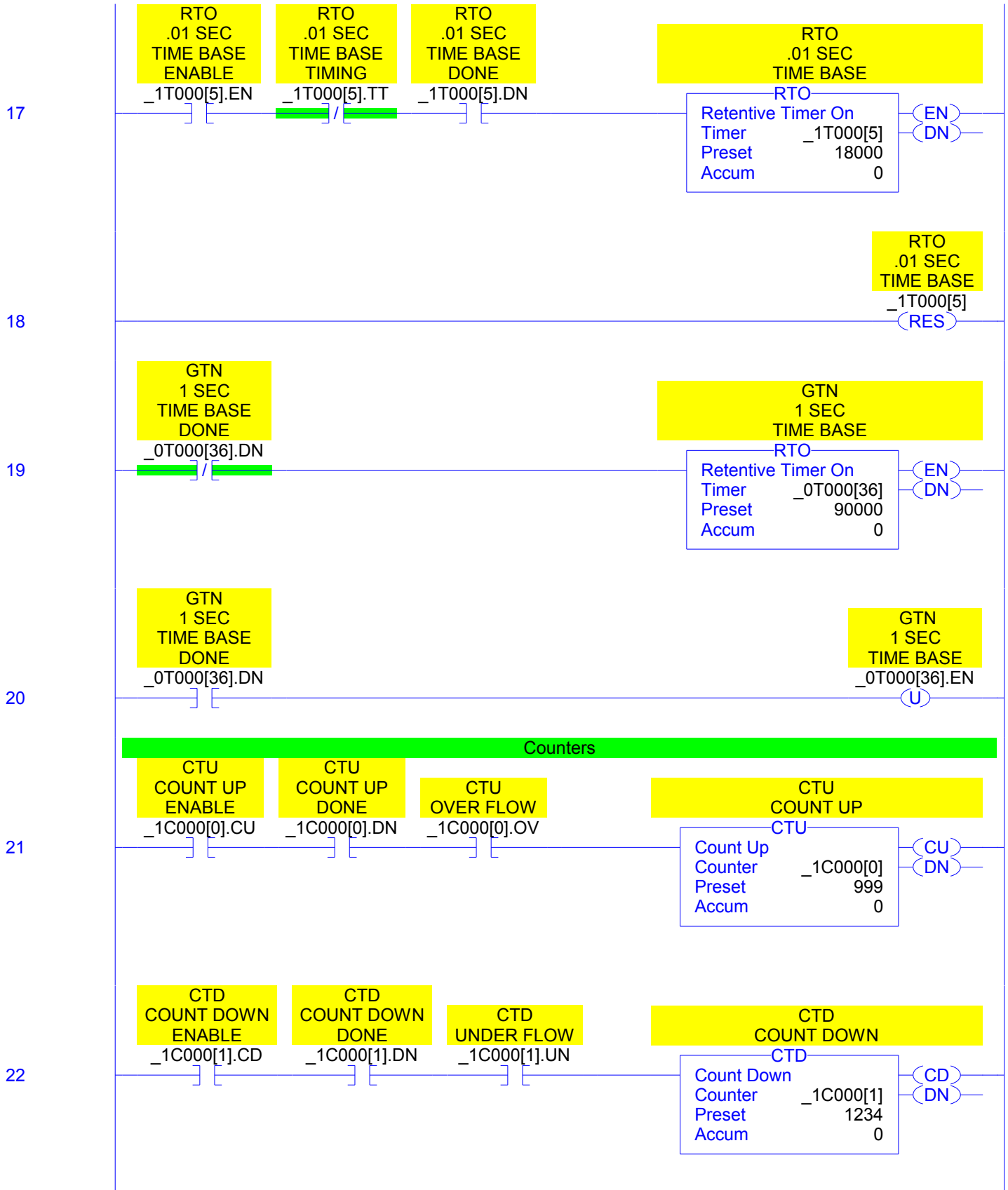

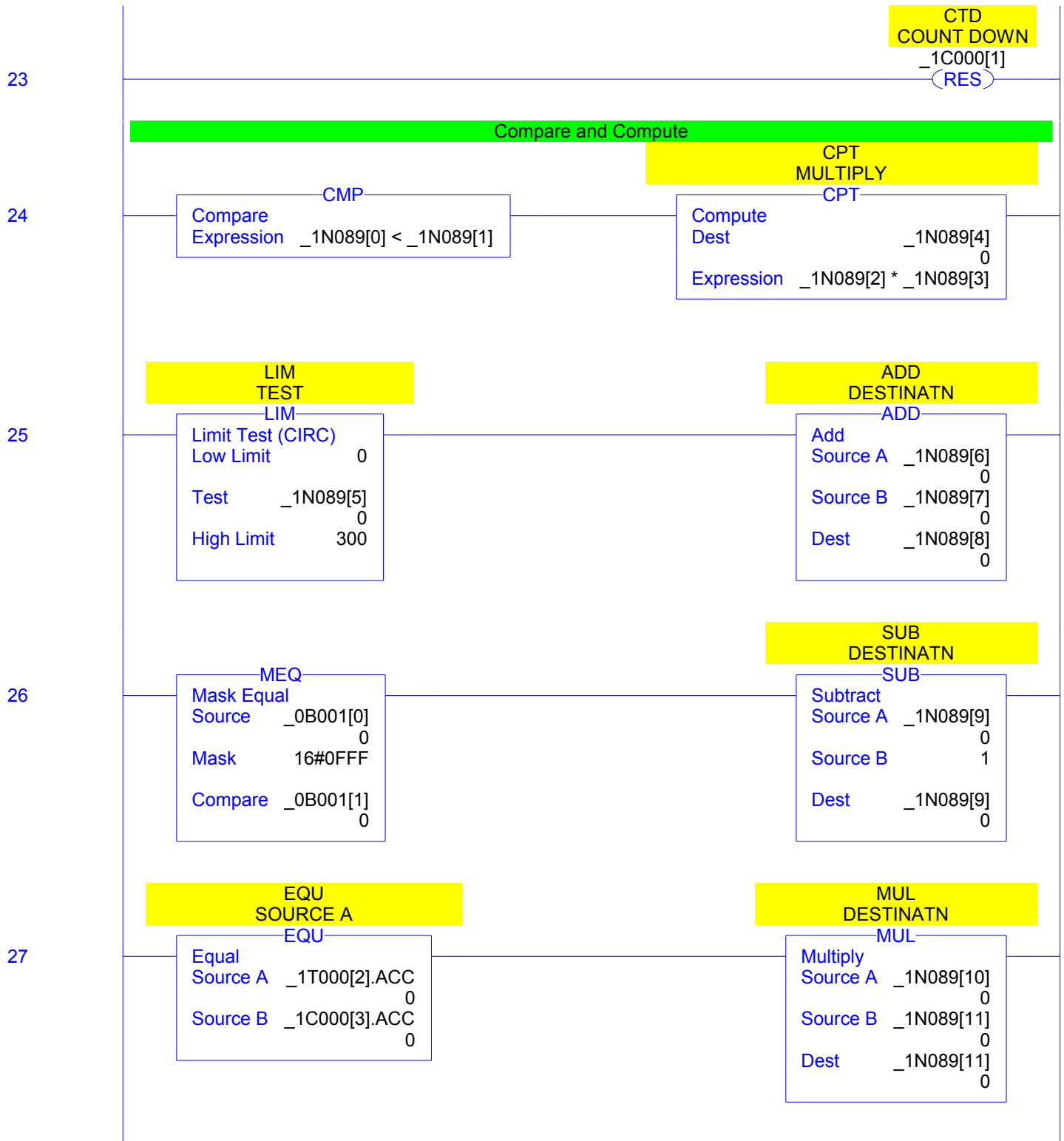

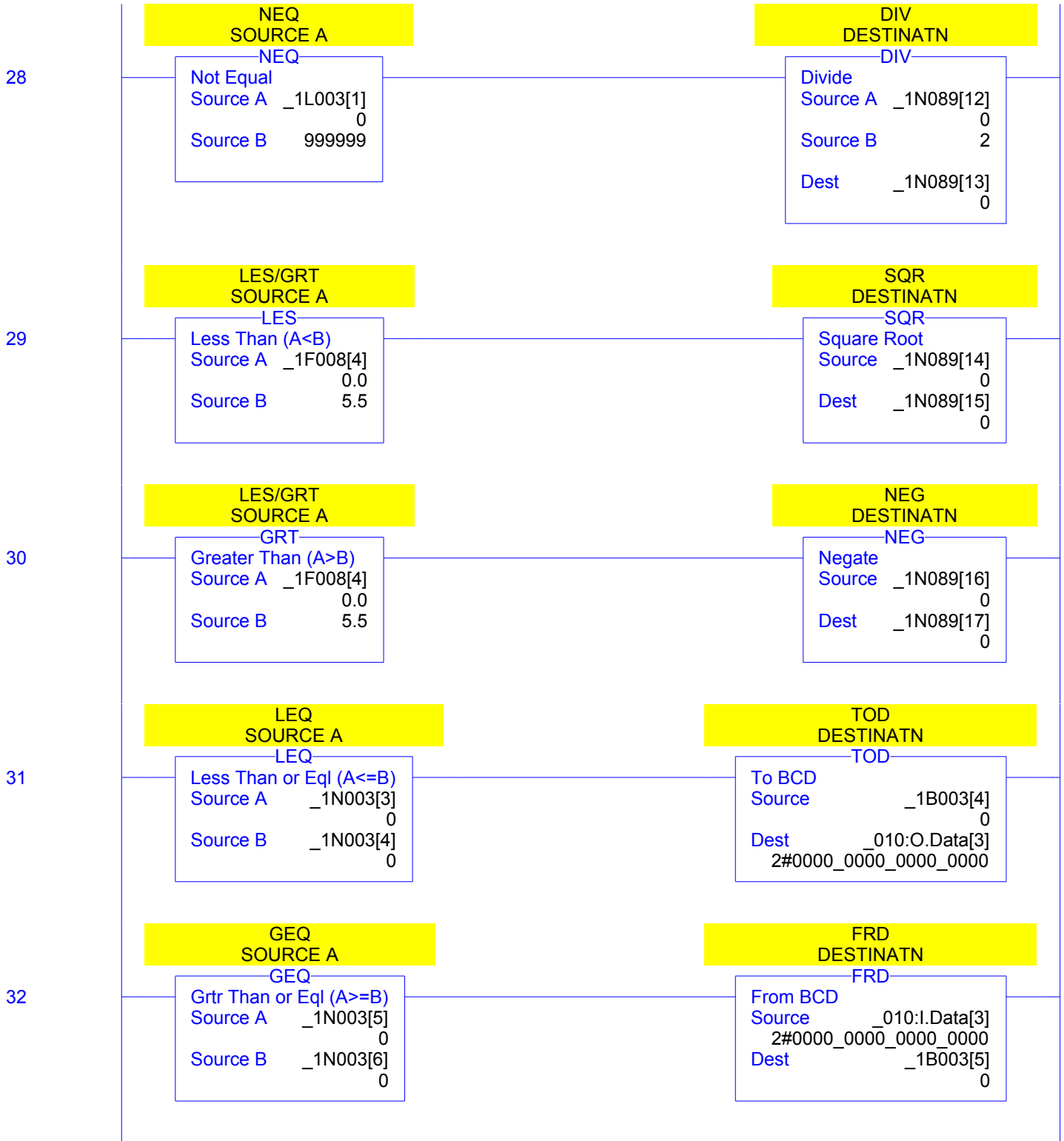

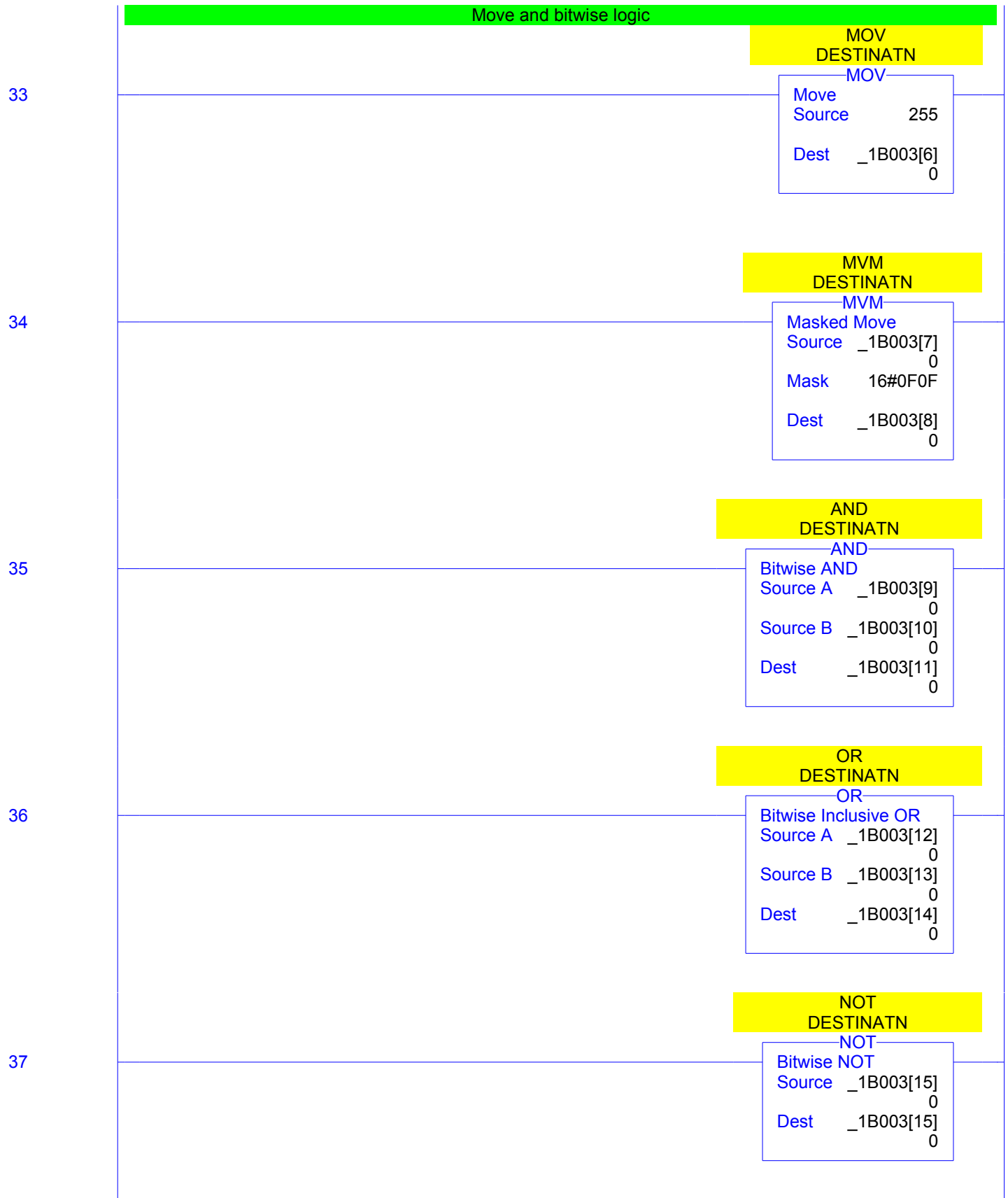

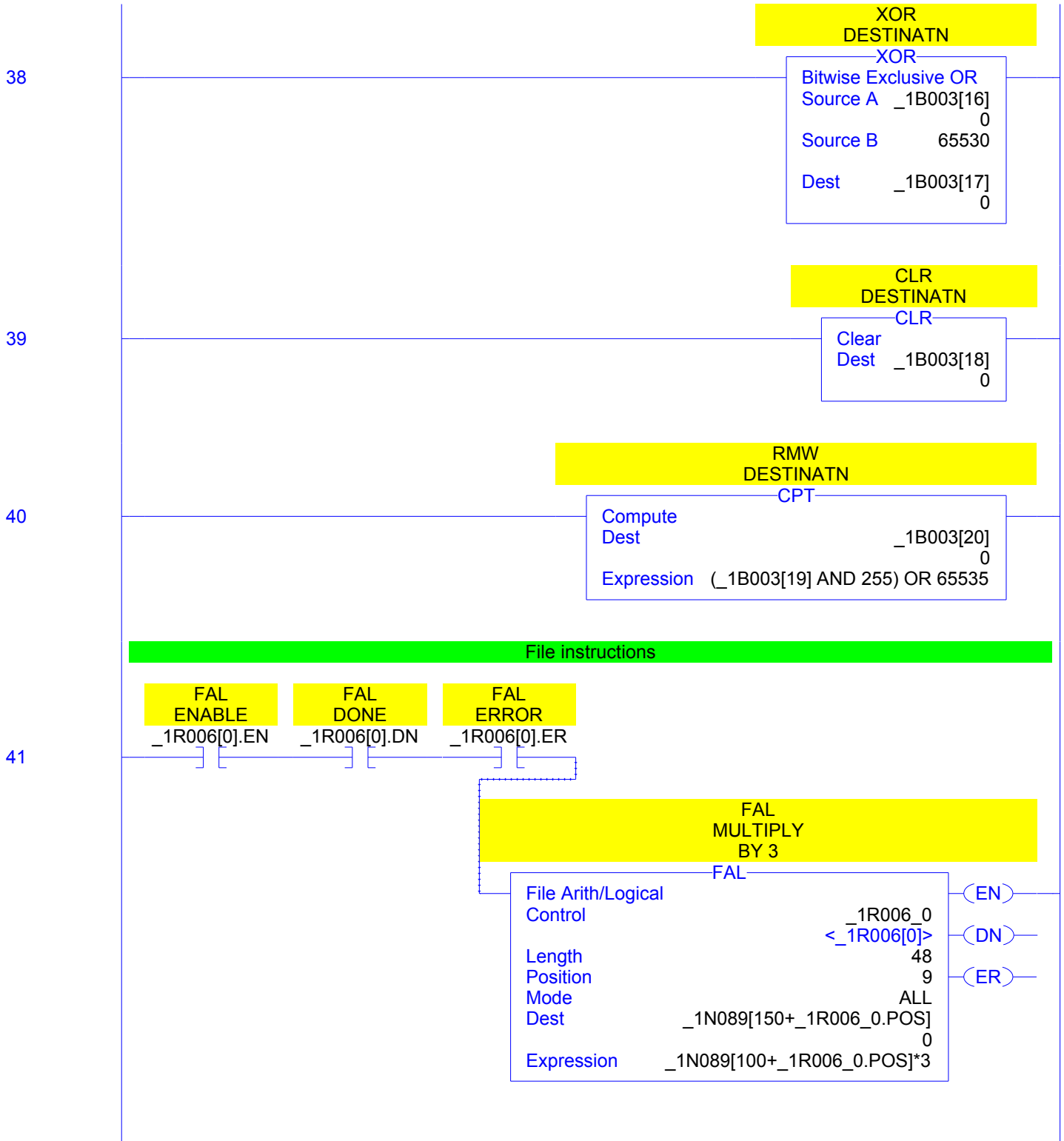

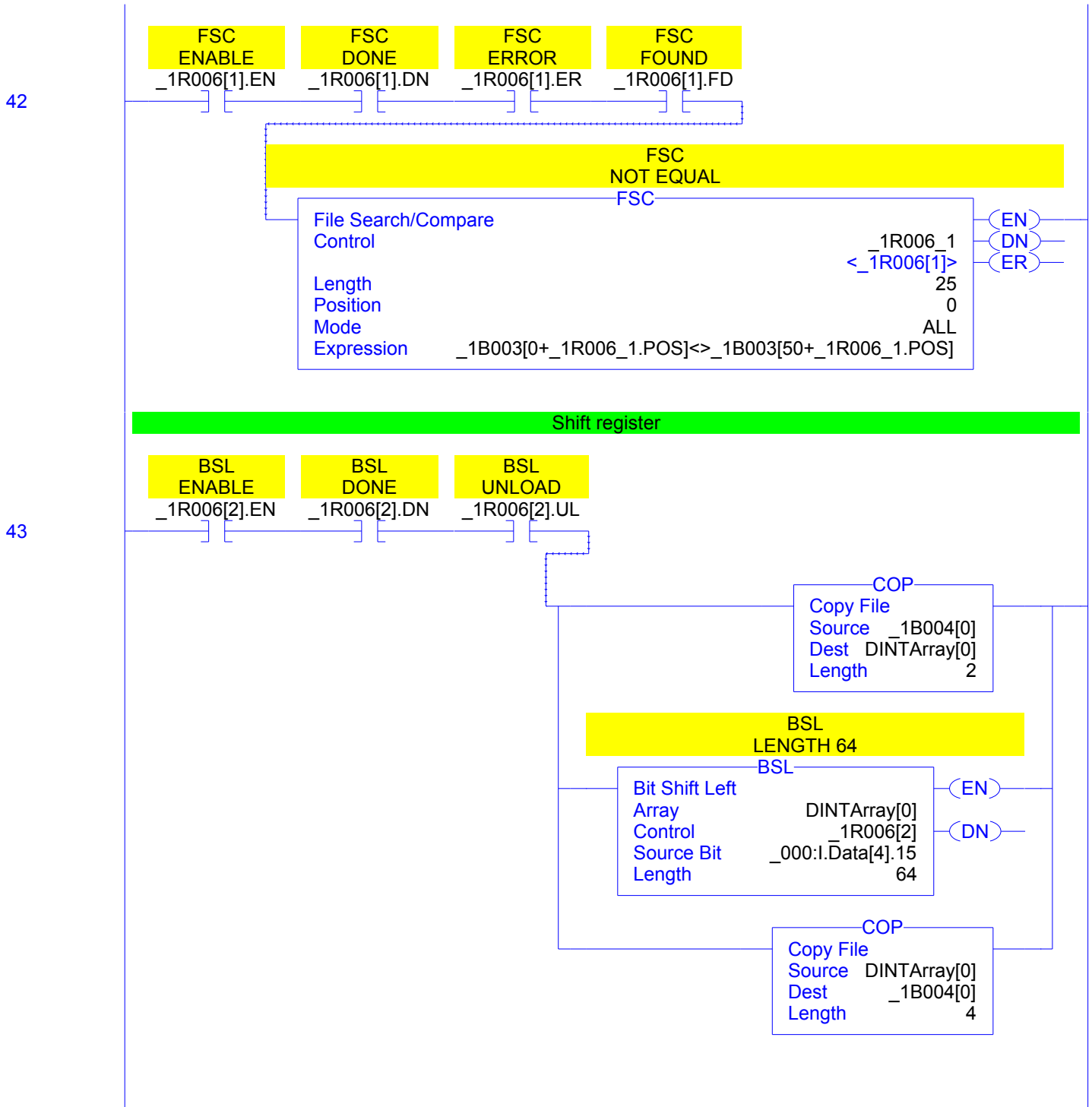

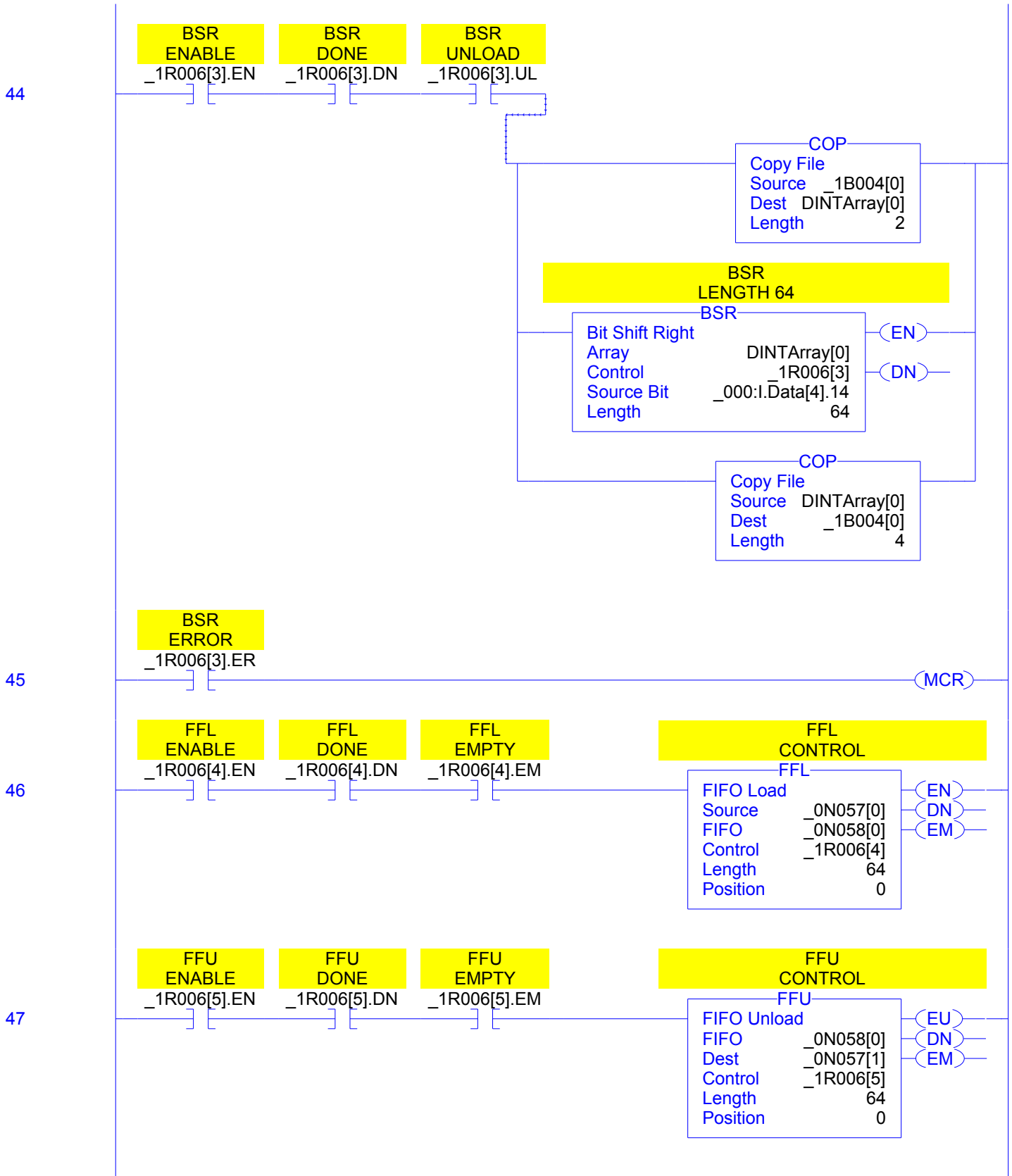

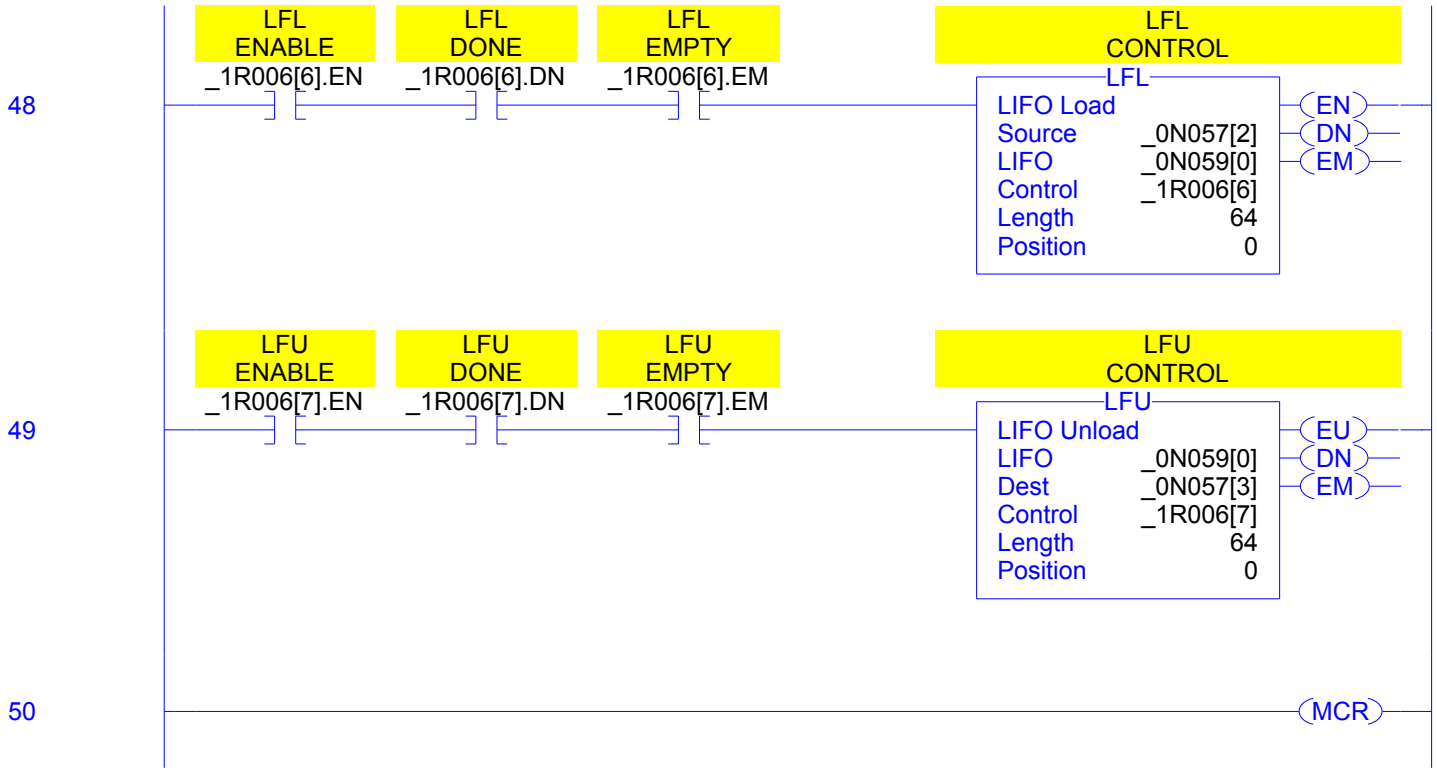

51

